

A Proton Precession Magnetometer

B. N. BHARGAVA* and G. A. KASIVISWANATHAN

Astrophysical Observatory, Kodaikanal

(Received 25 September 1965)

ABSTRACT. A simple portable proton precession magnetometer designed and constructed for Kodaikanal Observatory is described. Except for the signal amplifier, the instrument is transistorized. The accuracy of measurement of absolute value of the earth's total field with the magnetometer is ± 1 gamma. The precession signal voltage from the sampling coil is amplified and squared by a Schmitt trigger circuit, the output of which drives 10 stages of binary dividers. The first pulse in the output of the chain of dividers opens a gate allowing pulses from a 100 Kc/s crystal oscillator to pass to a pulse counter. The pulse immediately following the opening pulse closes the gate. By suitable feed back of this closing pulse any following pulse is prevented from opening the gate again. For the next observation, a manual resetting is necessary. The number of 100 Kc/s pulses counted are used to compute the scalar field.

1. The Horizontal and Vertical force of the earth's field have been measured at Kodaikanal Magnetic Observatory for many years with a set of Q.H.Ms., B.M.Z., Kew Magnetometer and Earth Inductor. While Q.H.M. and B.M.Z. yield fairly consistent values of H and V respectively, these instruments do not provide absolute values and have to be recalibrated at intervals of a few years. Kew Magnetometer and Earth Inductor do not yield values of H and V with sufficient accuracy and the duration of the experiments with these instruments, for one determination, is fairly long. Need, therefore, has been felt of an observatory instrument, capable of yielding accurate and absolute value of the earth's field in a very short interval of time. With this view, the development of a precession magnetometer was taken up in the electronics laboratory of the observatory.

The principle of working of the free precession magnetometer is simple. If protons in a suitable sample are magnetically polarized the applied field brings about a phase coherence. If, then, the polarizing current is abruptly switched off to satisfy the non-adiabatic conditions, the magnetic vector begins to precess about the earth's field. As a result, a signal of angular frequency ω is induced in a coil. This angular frequency is proportional to the strength of the field F and is given by —

$$\omega = \gamma_p F$$

where γ_p is the gyromagnetic ratio of the proton. Driscoll and Bender (1958) have determined the value of γ_p as $2.67513 \pm 0.00002 \times 10^4 \text{ sec}^{-1} \text{ gauss}^{-1}$. The amplitude of the induced sinusoidal voltage decreases exponentially as the protons return to their original state of random orientation. The actual measurements of the total field, there-

fore, consist in measuring the frequency of the induced signal quickly and precisely.

The growth of magnetization M_t , t seconds after application of the field is given by —

$$M_t = M (1 - e^{-t/T_1})$$

M being the equilibrium value, and T_1 the spin lattice relaxation time. The induced signal decays as $\exp(-t/T_2)$ where T_2 , called the Transverse Relaxation Time, is a function of proton sample, homogeneity of the magnetic field in the sample and the time of polarization. It is obvious that for a determination of the field, a sufficiently large time constant T_2 is necessary so as to maintain the phase coherence over an interval of time sufficient for measuring the frequency reliably.

2. The tuned amplifier and the 100 Kc/s source are wired on two separate metal chassis. The remaining units are made up of a number of modules one for each stage of divider, a gate with its driver etc. The modules are constructed on Hylam cards. The arrangement facilitates quick replacement of defective units. Two meters mounted on the panel show the on/off condition of the gates. The block diagram of the magnetometer is shown in Fig. 1. The principal units, *i.e.*, the sampling coil, switching circuit, amplifiers, frequency divider, gates, 100 Kc/s signal source and the pulse counter are described below in some detail.

The sensing coil and sample — A single multilayer coil was used both for polarizing the hydrogen nuclei and for picking up the precession signal. The principal requirements for the coil were (1) High Q , (2) lowest possible self capacitance and (3) largest possible enclosed volume. After several trials, a coil consisting of 500 turns of 17 s.w.g. enamelled copper wire in four layers was found to be satisfactory. The length of the coil was 18 cm and the inside diameter 11 cm. The proton source was

*Present address — Colaba Observatory, Bombay

distilled water in a glass container from which dissolved air was removed. With the coil oriented perpendicular to the magnetic field, a current of 7 amp. drawn for about 7 seconds from an 18 volt source produced a signal which was found to be well above the noise for about 4 seconds. A photograph of the coil is shown in Fig. 2.

The switching unit — The polarizing current is supplied to the coil by 55 feet of RG-8/U coaxial cable. The same cable transmits the signal to the preamplifier. This arrangement was carried out using a heavy duty polarize/read relay as a manually operated switch. To prevent switching transients from triggering the gate circuits a delay of about 300 milliseconds, provided by an auxiliary relay, was incorporated. A suggestion by Waters and Francis (1958) on the inclusion of a damping resistor across the coil during the delay interval was found very useful in obtaining consistent readings on the counter. The switching arrangement is shown in Fig. 3.

The amplifiers — The average value of the magnetic field at Kodaikanal is of the order of 39,800 γ . The precession frequency anticipated was, therefore, of the order of 1695 cps. The requirements of the preamplifier were of detection and amplification of a few microvolts of signal at this frequency. A "Twin-Tee" amplifier was developed for a centre frequency of 1700 cycles with a good signal-to-noise ratio. Satisfactory performance was achieved after considerable experimentation. Use of batteries for both L.T. and H.T. supplies reduced the noise considerably. The signal was fed to the 12AX7 preamplifier through matching transformer with the primary series tuned with the sensing coil on the lines indicated by Cahill and Van Allen (1956). A wide band L-C tuned circuit was used for coupling the two triodes. Negative feed-back was applied to the grid of the 6BH6 pentode through a "Twin-Tee" network. The overall voltage gain of the amplifier was 10^6 for input signal amplitude not exceeding 5 μV . Since one cycle of precession frequency corresponds to approximately 23.487 γ , the bandwidth of the amplifier was adjusted to about 100 cycles to

measure the field within sufficiently wide limits. The circuit diagram of the preamplifier is shown in Fig. 4. The output of the preamplifier was fed to two-stages of emitter followers with an intermediate grounded emitter stage. The following stage was a pulse shaper. A Schmitt trigger using 2N404 switching transistors yielded a square-wave signal of constant amplitude suitable for frequency division. The circuit diagrams of the divider-amplifier and pulse shaper are shown in Fig. 5.

The division was carried out by a chain of 10 binaries yielding output pulses of frequency which was 2^{-10} or 1/1024 of the precession frequency. The schematic diagram of one stage of binary is shown in Fig. 6. The successive pulses for a precession frequency of 1695 cps occurred at intervals of approximately 0.6 sec. The pulses at this stage pass through signal gate, kept open initially by manual operation of a "signal gate" switch. The first positive pulse entering through the signal gate opens a "counter gate" allowing the 100 Kc/s signal from the crystal oscillator to pass on to the pulse counter. The succeeding positive pulse entering through the signal gate closes, both the counter gate and the signal gate. This operation stops the flow of 100 Kc/s pulses to the counter and at the same time prevents succeeding pulses, if any present, from reopening the counter gate. The counter read-out yields the interval between two successive pulses. The resolution time of the counter is 5 μs . 16 stages of binary division are used on the counter. For a magnetic field of 39,800 γ , approximately 60,400 counts are registered. The schematic diagrams of the gating circuits and the 100 Kc/s oscillator are shown in Figs. 7 and 8 respectively. The crystal oscillator is adjusted to 100 Kc/s at frequent intervals using standard frequency transmissions from WWVH or JJY. With the accuracy of pulse counts of ± 1 in 60,000, the observed value of the earth's field is correct to within $\pm 1 \gamma$.

Acknowledgement

The authors are grateful to Dr. M. K. Vainu Bappu, Director, for his suggestions and constant interest and to Mr. A. P. Jayarajan for his help in the fabrication of the sensing unit and several parts of the magnetometer.

REFERENCES

- | | | |
|------------------------------------|------|---|
| Cahill, L. J. and Van Allen, J. A. | 1956 | <i>J. geophys. Res.</i> , 61 , p. 547. |
| Driscoll, R. L. and Bender, P. L. | 1958 | <i>Phys. Rev. Lett.</i> , 1 , p. 413. |
| Waters, G. S. and Francis, P. D. | 1958 | <i>J. Sci. Instrum.</i> , 35 , p. 88. |

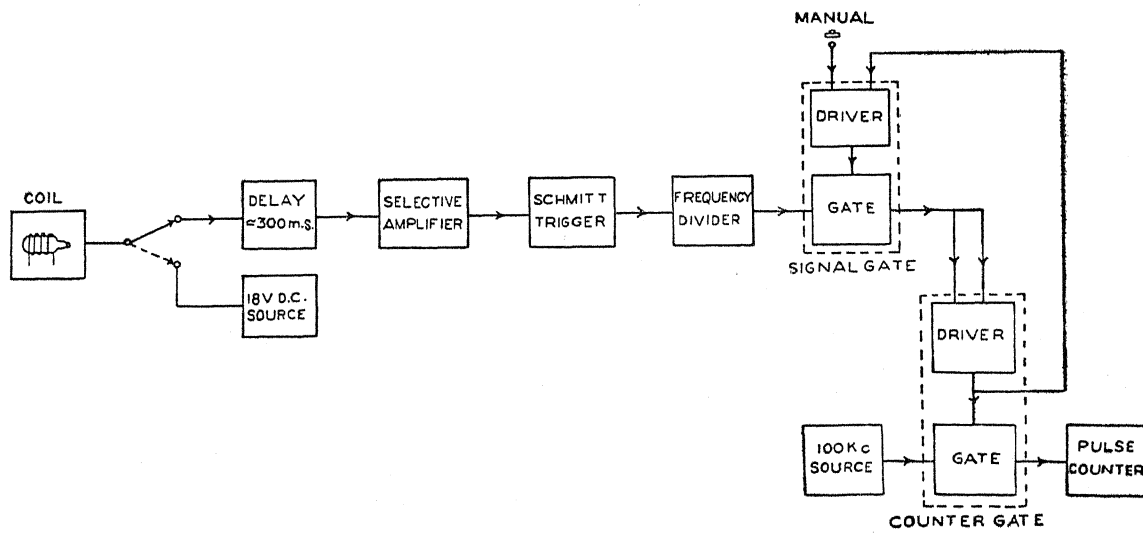

Fig. 1. Block diagram of the magnetometer

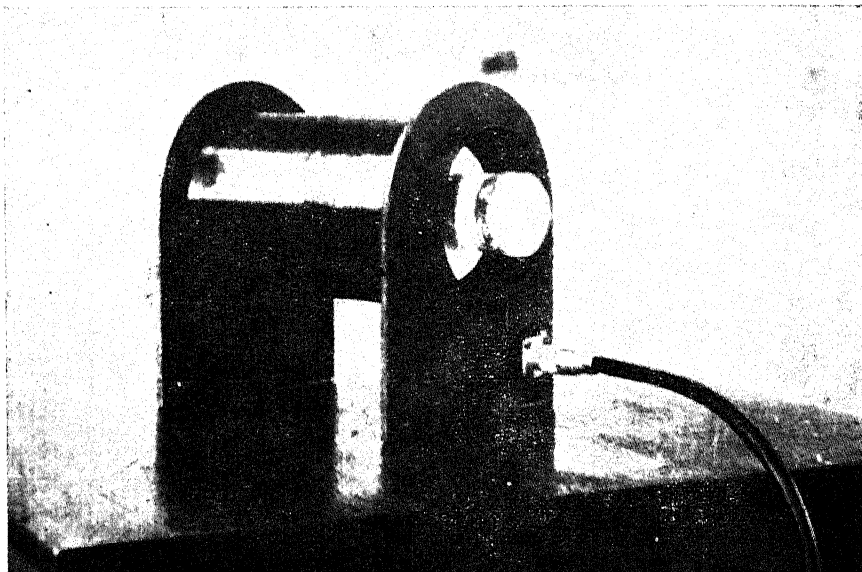

Fig. 2. Polarising/Sensing Coil

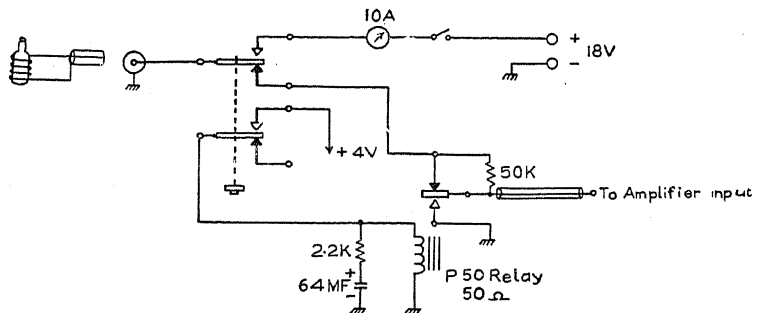

Fig. 3. Coil switching arrangement

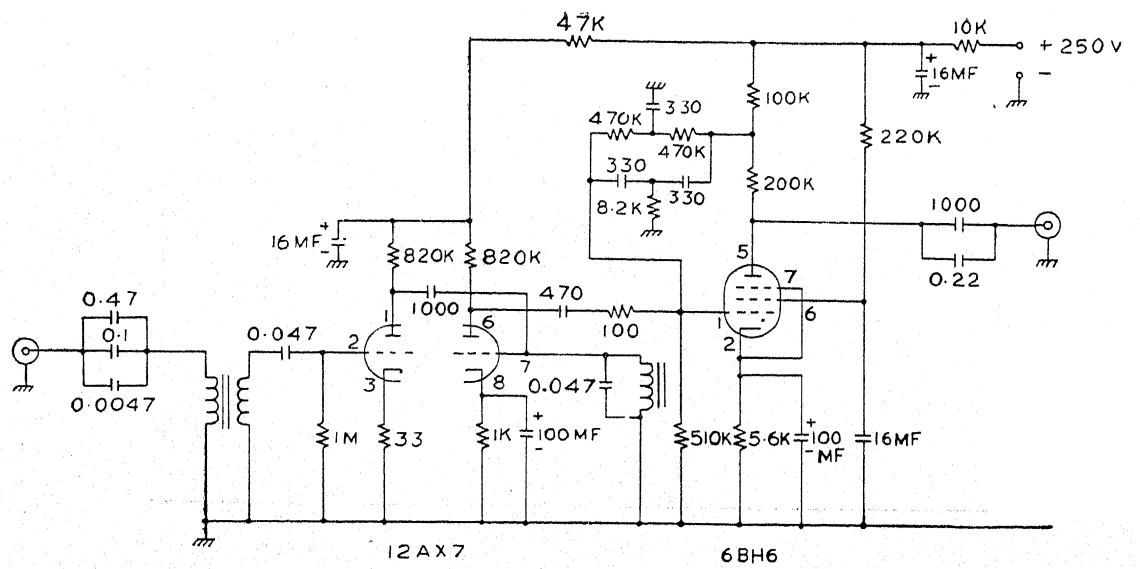

Fig. 4. Preamplifier

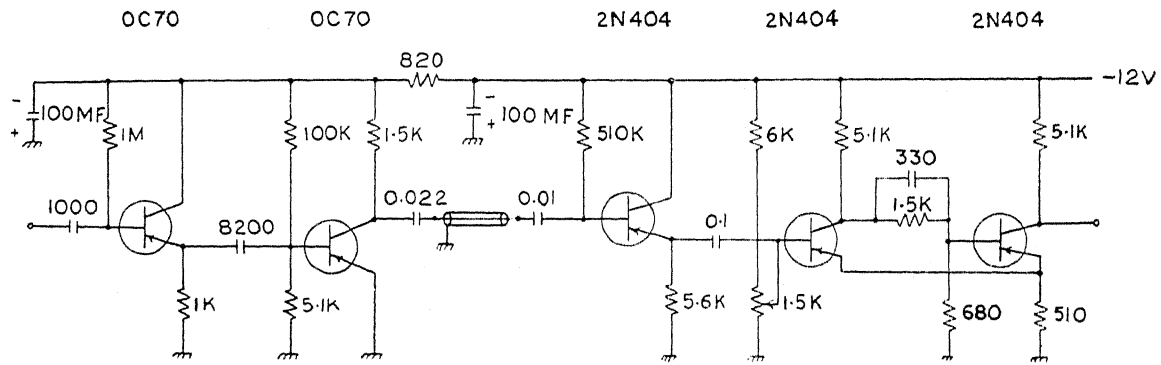

Fig. 5. Divider amplifier and pulse shaper

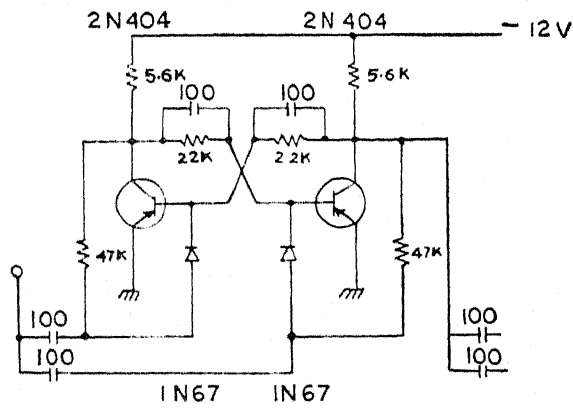

Fig. 6. Binary Divider

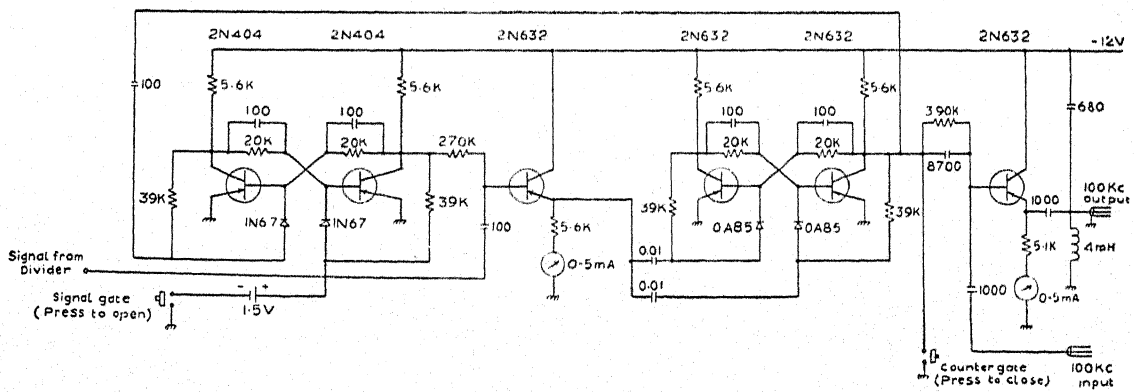

Fig. 7. Gating circuits

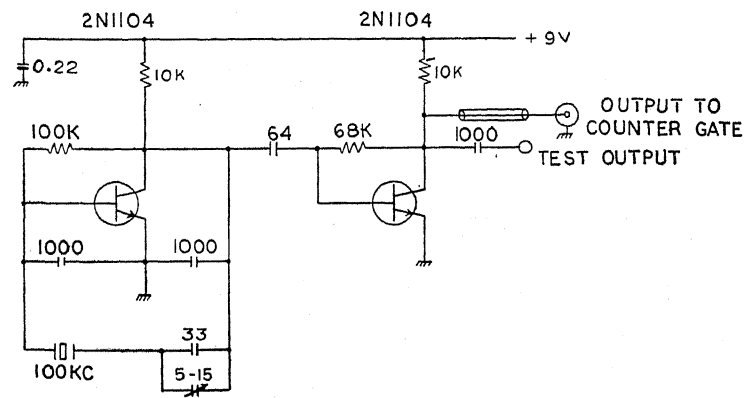

Fig. 8. 100 Kc/s oscillator