

Madras Observatory : Buildings and instruments

R. K. Kochhar *Indian Institute of Astrophysics, Bangalore 560 034*

Received 1985 April 20; accepted 1985 May 20

Abstract : We describe the buildings and the chief instruments of the Madras Observatory (1786–1898), the precursor of the present Indian Institute of Astrophysics through Kodaikanal Observatory.

Key words : Madras Observatory—Indian Institute of Astrophysics—history of astronomy

1. Introduction

Madras Observatory was set up in 1786 as a private observatory by William Petrie, an officer of the British East India Company¹. The observatory was handed over to the Company in 1789 when Petrie left for England on one of his periodic visits.

Michael Topping, who took over from Petrie in 1789, was the Company Astronomer and Marine Surveyor. His monthly salary as Astronomer was 192 pagodas (1 pagoda \approx 3.5 rupees). John Goldingham assistant to Topping since 1788 succeeded him in 1796. Goldingham was also Marine Surveyor, Inspector of Revenue Board (since early 1797), and Superintendent of Surveying School. He also held for a short period (1800–1) the surprising post of Civil Engineer, with charge of civil buildings and construction (ref. 1a; cf. ref. 1).

Goldingham computed a value for the longitude of the observatory as $80^{\circ} 18' 54''$, the derivation of which he explained in correspondence with Robert Hyde Colebrooke (Surveyor General of Bengal 1794–1808). Colebrooke pointed out that Goldingham's value might well be anything between $80^{\circ} 16' 30''$ and $10^{\circ} 21' 43''$. During Goldingham's medical leave (1805–11), John Warren held the Astronomer's and other posts. In 1807 Warren deduced a revised value for the longitude, $80^{\circ} 17' 21''$ E, which was used for all official maps till 1905.

On the appointment of Colin Mackenzie as the Surveyor General of Madras from 1810 December 1, the post of Inspector of Revenue Surveys was abolished, and the Surveying School closed down; and John Warren remained only the Astronomer. The Observatory was placed under the general control of the Surveyor General.

In his second tenure (1811–1930) Goldingham was appointed Superintendent of the Male Asylum on a monthly salary of Rs. 150, as well as Inspector of Government Press and Editor of Government gazette for which duties he drew a further Rs. 100 every month (ref. 1a).

The observatory had a chequered history for more than a hundred years at Madras, till in 1899 the astronomical activity was shifted to Kodaikanal where a new, solar physics observatory was established. Madras observatory was in charge of nine directors, from Petrie to C. Michie Smith who moved to Kodaikanal in 1898 (table 1).

Table 1. Directors of Madras Observatory 1786–1898

1. 1786–1789	William Petrie	(d. 1816)
2. 1789–1796	Michael Topping	(b. ~ 1747 d. 1796)
3. 1796–1805	John Goldingham	(b. 1765/6 d. 1949)
1812–1830		
4. 1805–1811 (acting)	John Warren	
5. 1830–1848	T. G. Taylor	(b. 1804 d. 1848)
6. 1849–1858	W. S. Jacob	(b. 1813 d. 1862)
7. 1859–1860	J. F. Tennant	(b. 1829 d. 1915)
8. 1861–1891	N. R. Pogson	(b. 1829 d. 1891)
9. 1891–1911	C. Michie Smith	(b. 1854 d. 1922)

2. The building

2.1. The 1792 building

From its inception in 1786 till 1791, the observatory was housed in a part of the Astronomer's residence. The observatory building was constructed in 1792 on the banks of river Cooum in Nungambakkam, about 120 yards south-west of the Astronomer's residence. The architect of the building was Michael Topping. The construction was personally supervised by the assistant Astronomer, John Goldingham. We read in his manuscript description of the building³ :

'The closest attention was paid to purchasing the Materials, to cleansing and mixing the chunam with a proper quantity of jaggery (or sugar) and to allowing the work proper time to settle'.

The details about the observatory we get not so much from Goldingham's manuscript volume³, the first 10 and the last few pages of which are missing, as from the first volume of Taylor's (1831) observations^{4a}, published in 1832, and from the volume of Pogson's (1862–1864) observations⁵, published in 1887.

The 1792 observatory building consisted of a single room 65 ft long (east-west), 20 ft broad and 14 ft high. The walls were over 2 ft thick and supported the roof. In the middle of the building, insulated from it and 1 ft below the floor level was a solid pyramidal mass of brickwork, as solid as a rock. The pyramid on which the instruments rested was 6 ft deep, 37 ft × 6 ft at the top, and 45 ft × 12 ft at the base.

In the centre of the building was a conical granite pier 4 ft in diameter at its base tapering to 2 ft diameter at its total height of 18 ft, *i.e.*, 4 ft above the roof. The pier certainly weighed not less than 10 tons. On the pier were inscribed the words Michael Topping, Arch. AC MDCCXCII.

On a granite tablet over the western door of the observatory was the following inscription³ :

ASTRONOMIÆ confectatum
 sumplibus Societatis Angliæ
 in INDIA mercaturæ faciendæ
 favente CAROLO OAKLEY Bar.^{to}
 Præfecto Præfidii Sancti Georgii
 AD MDCCXCII

Translations of this in English, Tamil, Telugu, and Urdu were inscribed on the granite pier, so that, as Goldingham grandiosely wrote³,

‘Posterity may be informed a Thousand years hence of the period when the Mathematical Sciences were first planted by British liberality in Asia’.

Figure 1 shows a sketch of the observatory building, taken from Goldingham’s 1792 manuscript³. Some pillars and platforms were added in 1806 (ref. 6a). Figure 2, taken from *Philosophical Transactions* 1822, shows the interior of the observatory in 1821 with Goldingham swinging a Kater’s pendulum hung before a Haswell (also spelt Haswall) clock. Figure 3 shows a sketch of the building taken from the cover of the volume of Taylor’s 1843–47 observations^{4c} (published 1848).

In 1845 the observatory building was extended⁵, both east- and west-wards when the magnetic and meteorological establishments of the Madras government—set up in 1840 on the recommendation of the Royal Society, London—were merged with the observatory. The original room of the observatory became the transit room, and the building was now an inelegant 196 ft × 20 ft (ref. 5). Figure 5 shows a schematic sketch of the extended building, based on Pogson’s 1887 description⁵.

Eastward were added : first, a covered passage (20 ft × 8 ft) leading to the dip-circle room (26 ft × 26 ft); next, a magnetic room (45 ft × 15 ft) in which the bifilar, vertical force, and declination magnetometers were placed and read every hour up to 1861 March; and third, a small transit-theodolite room (16 ft × 12 ft) used by the head magnetic assistant.

About 30 ft more eastward was erected a small detached room (22½ ft × 15 ft) used only for periodical determinations of the absolute horizontal force.

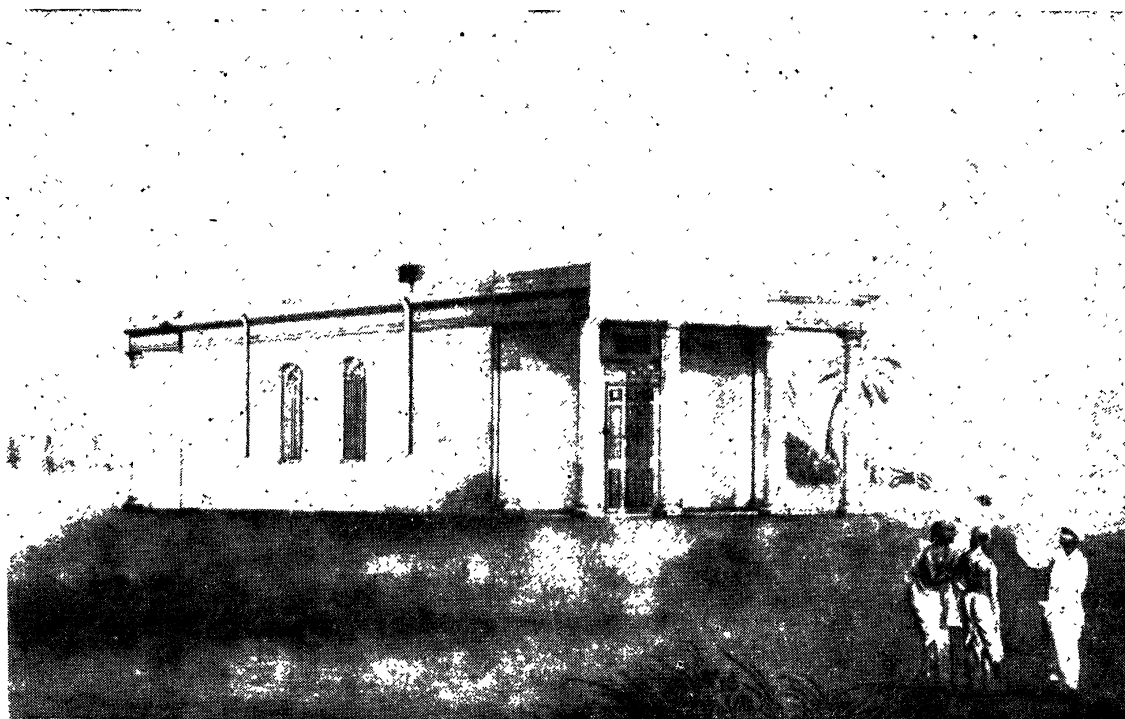

Figure 1. A sketch of the observatory building, from Goldingham's manuscript³ 1792.

Westward of the old room (the transit room), were added two rooms, 20 ft \times 15 ft each; the first was used as a computing and manuscript room, and the other as a store room for instruments and other property not in actual use.

In 1872 three rooms were hurriedly constructed on top of the transit room, for celestial photography and just in time to photograph the annular solar eclipse of 1872 June 6.

On the large central granite 18 ft high pier, unused since 1830, was mounted a fine 9-inch silver glass reflector by John Browning. A room 21 ft \times 15 ft was built to enclose the telescope. A flat sliding shutter was provided which when rolled off westward left a square opening of 10 ft, giving the reflector a fair command of the sky except near the horizon where it was never likely to be used for photographic purposes.

On the two sides of the reflector room was constructed a room each, a dark room for developing and the other for printing and other purposes.

2.2. *The Astronomer's residence*

The Astronomer's residence covering a space of 75 ft \times 50 ft housed the whole of the observatory from 1786 to 1791, and continued to be used for official purposes even after the observatory building was constructed in 1792. The earliest, and probably the only, description of this building is the volume of Pogson's 1862–1864 observations published in 1887 (ref. 5).

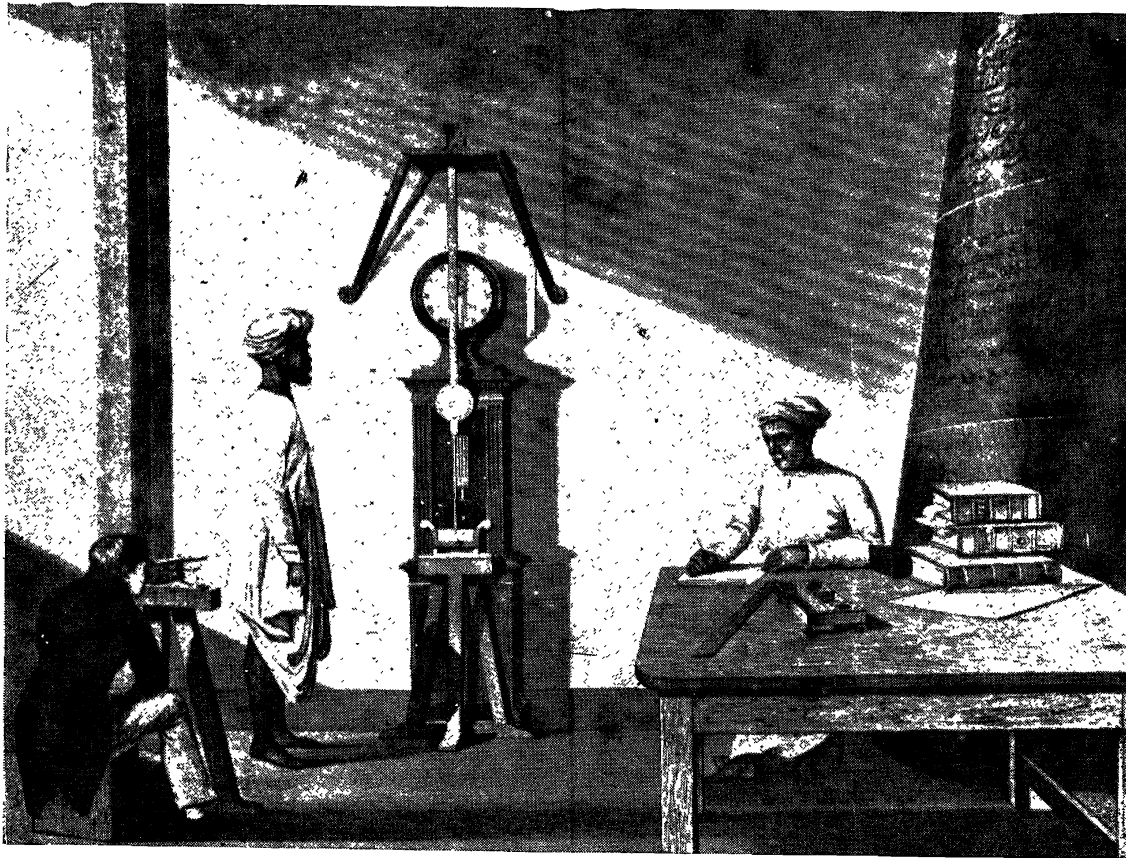

Figure 2. Goldingham swinging in 1821 a Kater's pendulum hung in front of a Haswell clock in the observatory. The second assistant, Thiruvenkatachary, is reading the clock, while the first assistant, Srinivasachary, sitting near the 18 ft granite pier, is noting down the reading (*Phil. Trans.* 1822).

'The house, originally provided for the Astronomer's use only, is a still older and more substantial building than the observatory proper already described, and much of it is now given up for purely official purposes. It contains in all eighteen rooms, eight on the ground floor; seven on the first floor and three on the roof. The ever increasing and already valuable and extensive library occupies two rooms on the ground floor, and in these also are placed the electrical clock and telegraphic appliances used for giving true time to the local shipping and generally to all parts of India. A granite step of the north-east door of the library is a benchmark of the Great Trigonometric Survey of India and is 22 ft above mean sea level. The private office of the Astronomer is immediately over the library, and on the roof are, a small anemograph room, 10½ ft square; a 16 ft circular room with an excellent revolving dome, containing a five eight-inch equatorial by Messrs. Troughton and Simms, and another smaller but similar room, for the six-inch equatorial by Messrs. Lerebours and Secretan, formerly used to such good purpose by Captain Jacob in measurements of double stars and Saturn's satellites'.

Pogson planned to include in the volume⁵ photographs or drawings of the buildings and of the chief instruments, but deferred them 'for the present'. They were never published.

3. Major instruments

To begin with, the observatory was rather modestly equipped. It started in 1786 with the instruments donated by William Petrie¹: a pendulum clock by Shelton; a



Figure 3. A sketch of the observatory building from 1848 volume of Taylor's observations^{4c}.

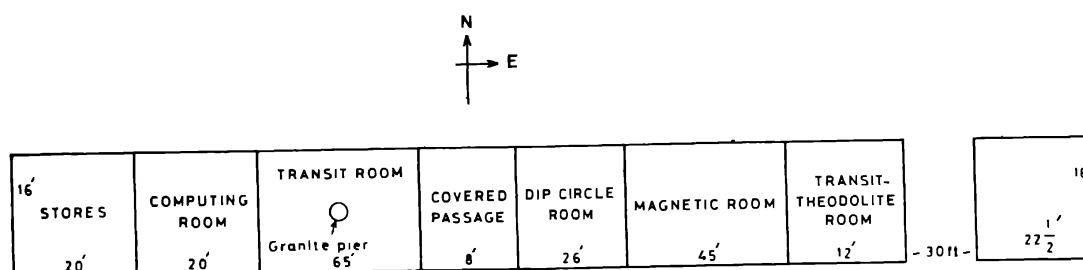

Figure 4. A schematic drawing, after Pogson's 1887 description⁵, showing the observatory building after the 1845 extensions. The detached room on the east was occasionally used for determination of the absolute horizontal force.

small (20 inch) transit instrument by Stancliffe; a quadrant by Bird; and three identical $2\frac{3}{4}$ inch aperture, $3\frac{1}{2}$ ft focus, Dollond achromatic telescopes with triple object glasses but without micrometers.

To these were added a 12 inch diameter circular instrument (altazimuth) by Troughton similar to that 'lately contrived by Mr [Jesse] Ramsden³ [John Dollond's son-in-law]; and a portable transit by Ramsden, purchased by Goldingham himself and gifted to the observatory in 1804.

The 12 inch Troughton circular instrument was mounted on the $10\frac{1}{2}$ ton, 18 ft high central conical pier and enclosed in a revolving dome, which can be seen in figure 3. The 20 inch Stancliffe transit and the (Shelton) transit clock both rested on granite supports each weighing $2\frac{1}{2}$ tons (ref. 3).

The observatory had, in addition to the Shelton transit clock, two astronomical clocks by Haswell and by Monk. Haswell clock was used by Goldingham in his pendulum experiments (figure 2) and is described in his 1822 *Philosophical Transactions* paper⁷ :

PLATE I

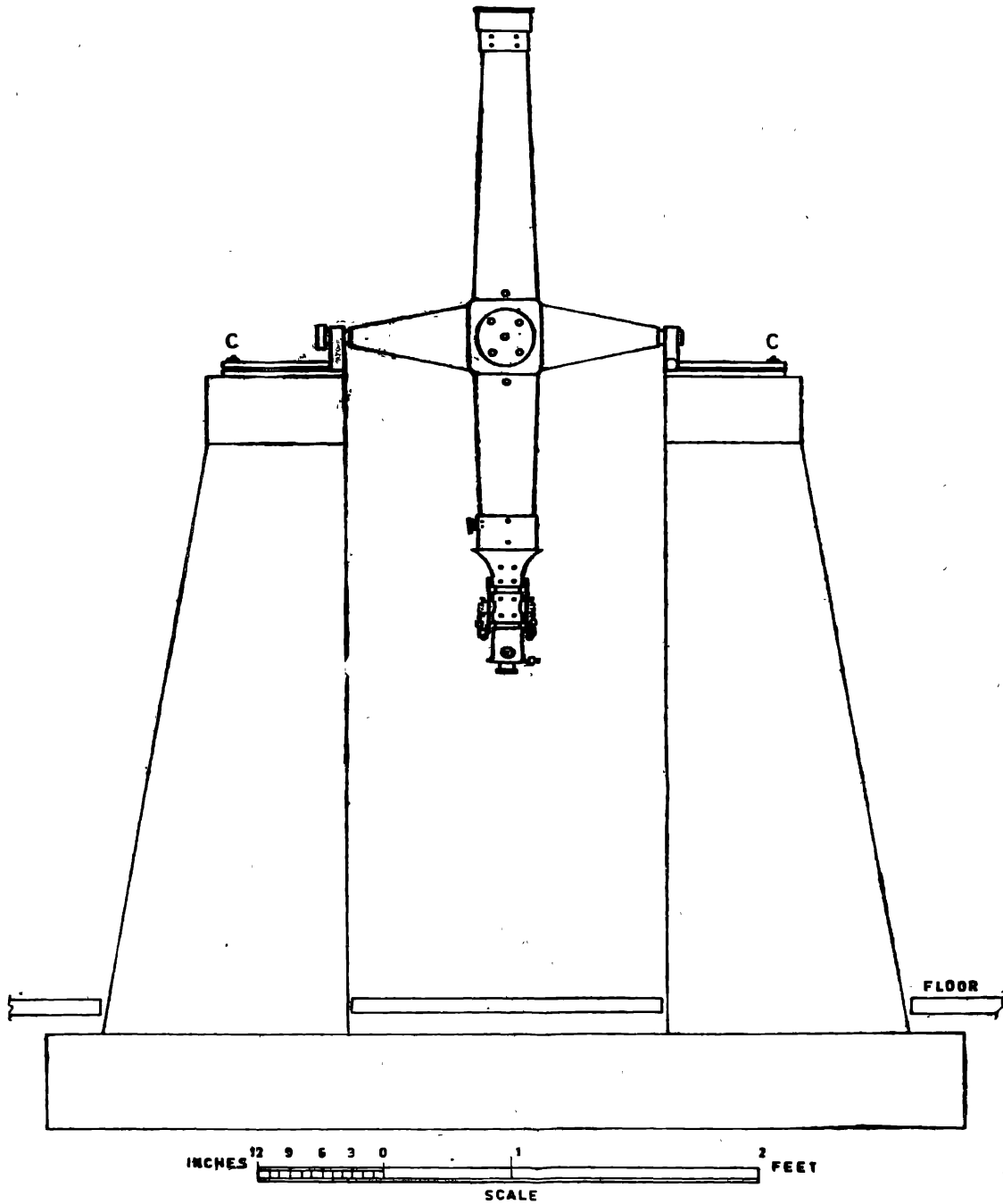

Figure 5. The 1830 transit instrument by Dollond, after a drawing in Taylor's 1831 volume^{1a}.

'The clock used in these experiments has a gridiron pendulum, the motion being given by a spring; the maker's name is Haswell, and the works are of the best description; it was fixed to the north wall of the observatory

The Monk clock was in use at the school set up in the observatory campus for training apprentices for survey work^{6b}.

Goldingham obtained 'six very good telescopes' expressly for observing eclipses of the satellites of Jupiter. Two were retained in the observatory, and the remaining four were sent out for obtaining correspondent observations (ref. 3).

In a letter dated 1807 March 5 to Colonel George Harcourt, John Warren, acting Astronomer since 1805, lamented⁸ :

'..... we have no instruments wherewith to take zenith distances. No telescope with a micrometer to measure small angles, or sufficiently powerful to sweep the heavens; in short nothing above a common Hadley's sextant to take an altitude or measure an angle of any sort. Our observations are, therefore, confined to transits and to observations of eclipses of various kind'.

An inventory^{6b} of the observatory property taken on 1812 April 1 includes in addition to the above mentioned instruments the following :

- Two pocket chronometers by Arnold, numbered 391 and 397
- Two sextants with horizons by Watkins
- One reflecting circle and stand by Troughton
- Two sextants with one stand and one horizon, by Troughton
- One solar microscope
- One thermometer by Troughton
- One brass sector
- One beam compass
- One hand spirit level.

3.1. *Transit instrument and mural circle, both by Dollond (1830)*

The two small instruments, the 20 inch transit instrument by Stancliffe and the 12 inch circular instrument by Troughton —'neither of them bearing an object glass of so much as an inch and a half in aperture'⁵—were the observatory's chief assets till 1829.

In 1830 the observatory acquired three new instruments^{4a} : a 5 ft (focus) transit instrument; a 4 ft (diameter) mural circle; and a 5 ft equatorially mounted telescope, all specially constructed by Dollond for Madras. These instruments had arrived in the summer of 1829, 'but by reason of absence of the Astronomer they were allowed peacefully to repose in their packing cases'^{4a} till Taylor's arrival on 1830 September 15. Taylor's first task was to dismantle the older Stancliffe transit and the Troughton altazimuth and to put the new instruments to use. He installed the transit instrument and the mural quadrant on the eastern and the western extremities of the pyramidal basement on opposite sides of the great central conical frustum, which was no longer used as a support for any instrument. It came in handy in 1872 to support the 9-inch Browning reflector which was used during the total solar eclipse of 1872.

The transit instrument and the mural quadrant were so fixed as to be opposite the two (18 inches wide) apertures in the roof which had hitherto been used with the old

instruments. The transit instrument was installed on the eastern end and rested on two pyramidal stone piers cut under Taylor's direction from blocks of an exceedingly hard quartzous stone (blue stone) brought from the Palavaram hills. The transit clock was also very steadily supported by a large block of blue stone.

The Dollond transit instrument (figure 5) had a focal length of 61 inches and a clear aperture of $3\frac{3}{4}$ inches. For the observations of the sun and bright stars, the aperture was occasionally reduced to $2\frac{1}{2}$ inches. A magnification power of 150 was employed. The eyepiece had one horizontal and five vertical fixed wires.

In the initial years a source of error was the unequal wear of the pivots. At the end of 1833 the pivots were fitted with collars of steel, which eliminated the wear^{4b}.

The Dollond mural circle (figure 6) was installed on the western end of the pyramidal basement^{4a}. It rested on $2\frac{1}{2}$ ft of new brickwork surmounted by four blocks of stone which were cut and sent out from England on purpose.

The mural circle, custom made for Madras, had a circle 48 inches in diameter, which was divided to every 5' and was read by four microscope micrometers. The object glass was of 49 inches focus and $3\frac{3}{4}$ inches clear aperture. The magnification power was 140. The eyepiece had one horizontal and five fixed wires.

'The new 5 ft focus, $3\frac{1}{2}$ inch aperture achromatic Dollond telescope was exceedingly well and steadily mounted on a mahogany frame armed with brass; and being supplied with two graduated circles and a long axis moving on a graduated arc, it has occasionally been employed as an equatorial in making rough observations out of the meridian in addition to its other uses in observing occultations and eclipses' (ref. 4a).

Taylor used these new instruments to prepare his celebrated 'Madras catalogue' which contained the positions of 11,015 stars reduced to the epoch 1835. It was based on observations made between 1831 and 1843 and formed the basis of Francis Baily's famous 1845 British Association catalogue. Madras catalogue was revised in 1893, from the original reductions deposited by Taylor in the record room of Greenwich Observatory, by Dr A. M. W. Downing, Superintendent of Nautical Almanac, with financial assistance from the Royal Society and India Office. The revised catalogue contained 10988 stars.

Taylor's successor Jacob used the transit instrument and the mural circle to revise the positions of 1440 stars of British Association catalogue, between north polar distance of 40° and 155° .

3.2. *Six-inch equatorial by Lerebours & Secretan (1850)*

The observatory's long felt need for a fixed equatorial telescope for extrameridional observations was fulfilled in 1850 with the private purchase of a 6-inch equatorial by Jacob at a total cost of over 500 pounds, which the East India Company reimbursed him when it took over the telescope⁹. The telescope is described in a volume¹⁰ of 1848-1852 Madras Observations, made by Captain W. K. Worster (acting Astronomer) and W. S. Jacob. The volume was published in 1854.

The six-inch telescope by Lerebours & Secretan of Paris reached Madras on 1850 March 22, and was erected and in use by 1850 April 12. The object glass had an aperture of 6.2 inches and 86.3 inches focus; it was found to be not only ill-centred

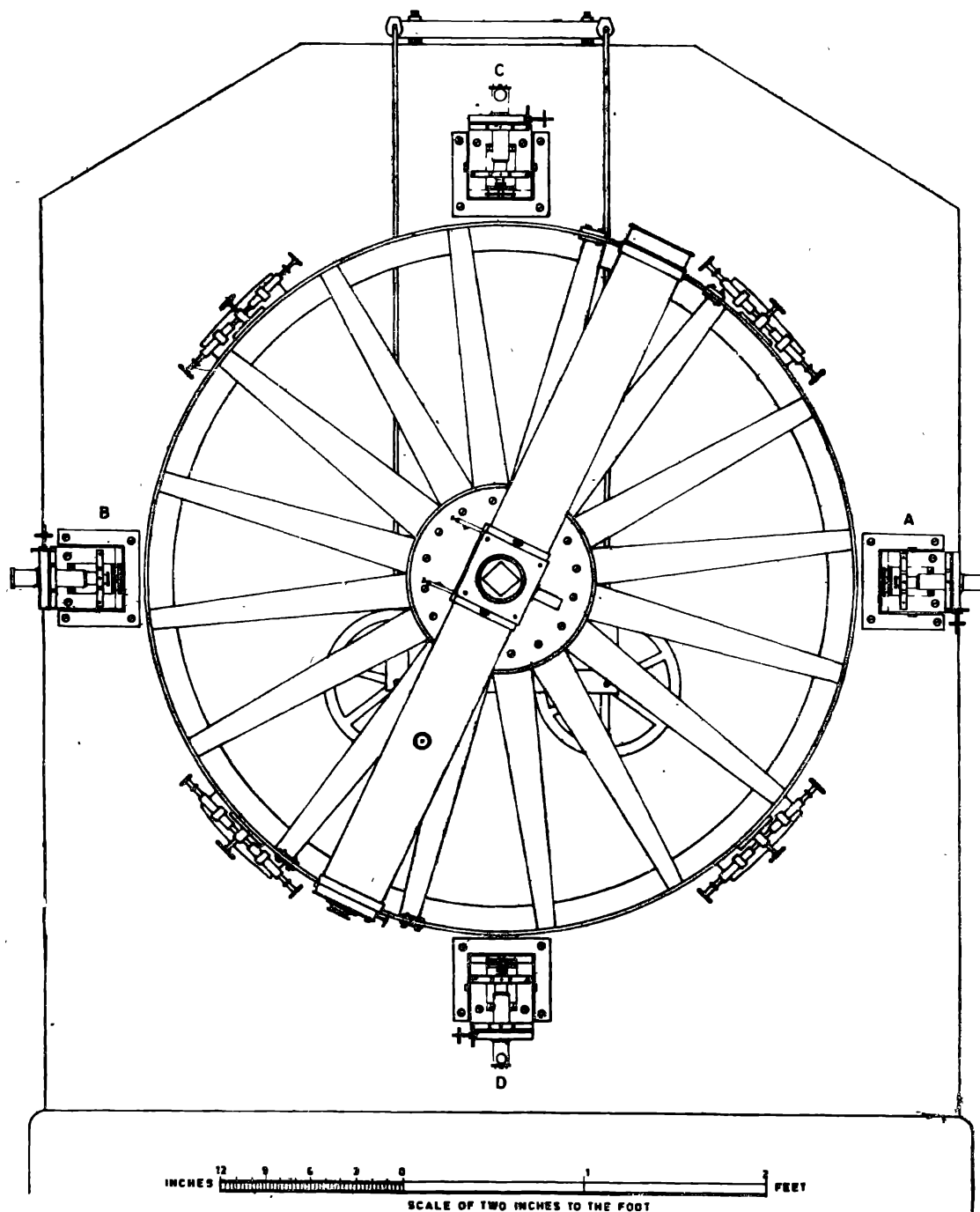

Figure 6. The 1830 mural circle by Dollond, after a drawing in Taylor's 1831 volume^{4a}.

but also to have several serious flaws and striae round the edge, preventing the use of an aperture larger than 4 inches except on very faint objects. The makers replaced the defective object glass and new one, of the same aperture but focal length of 88.64 inches, was received on 1852 July 23.

The telescope was mounted somewhat like the great Northumberland at Cambridge. The hour circle was of 13 inches diameter and read to 5s by one vernier; the

declination circle, of 14 inches diameter, was read to 30 arcsec by two verniers. The driving clock was German.

The original micrometer was rather of inferior quality, 'the screws being coarse and sensibly unequal, while the planes in which the wires move are separated so far as to cause a perceptible parallax'. Two other micrometer—Dollond's and Troughton's—(lent by General Fraser) were occasionally used. Two Huygenian eyepieces were furnished by the makers.

The telescope (figure 7) was mounted 'on stout wooden tressels firmly embraced' on the roof of the Astronomer's residence. Instead of a rotatory roof, a folding

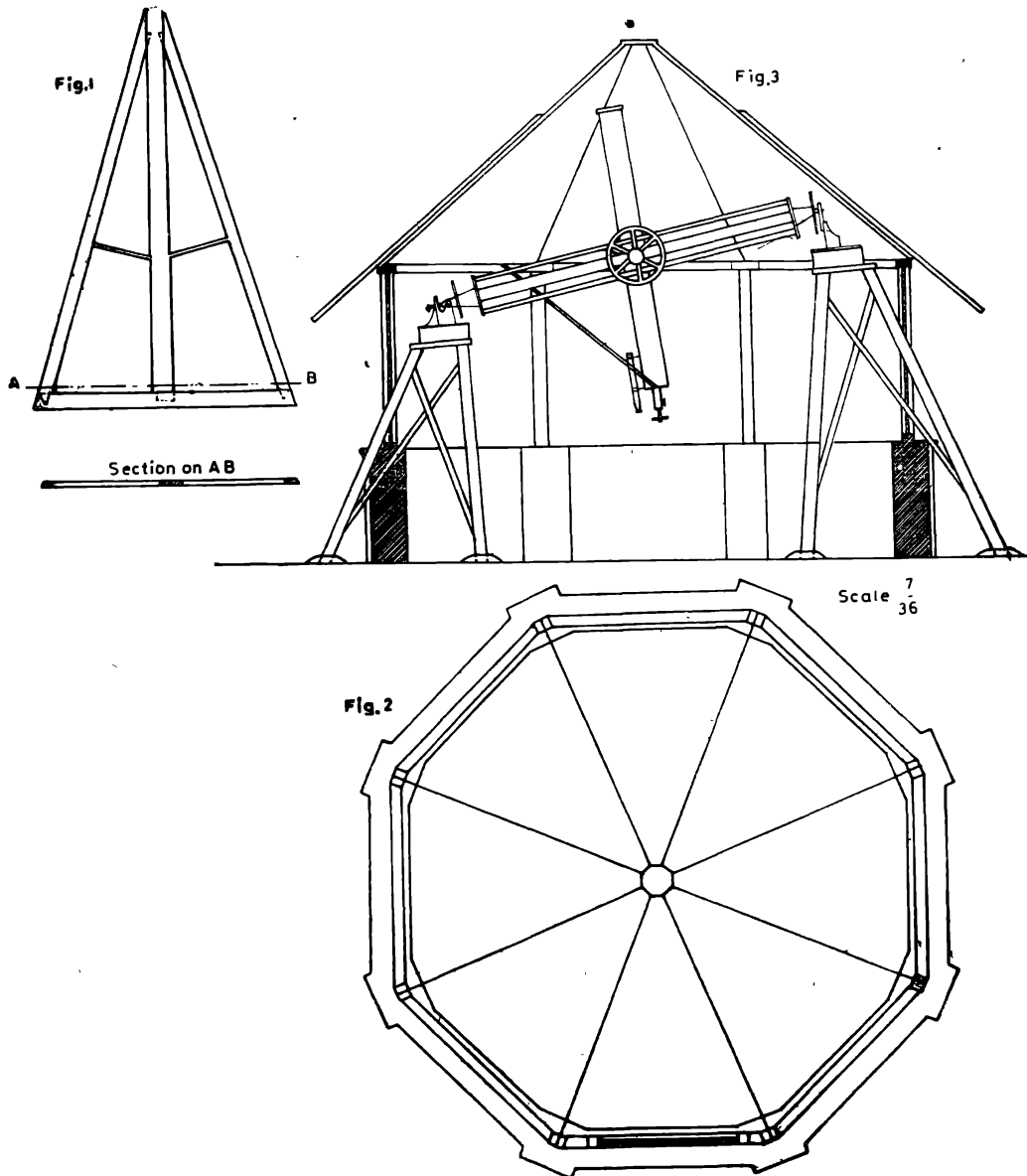

Figure 7. Six-inch Lerebours & Secretan equatorial telescope, from Worster & Jacob's 1845 volume¹⁰. The roof is a truncated octagonal pyramid formed of eight separate frames of teak of the form shown on top left. Plan (upper drawing) and sectional elevation of the building are shown. The telescope is now at Kodaikanal.

roof (made of teak wood) was erected, similar to the one Jacob had constructed at Poona, described in the *Monthly Notices of the Royal Astronomical Society* 1843 November, and brought to the notice of the British Association in 1850 by Professor C. P. Smyth.

The reasons for constructing such a roof in preference to rotatory one were two-fold. The first was economy. The telescope at that time was Jacob's personal property and was erected by him at his own expense not knowing if the arrangement would be permanent; it cost one-fourth of the cost of the cheapest kind of rotatory roof. Second, the building for the telescope being on the terrace was required to be as light as possible (ref. 10).

Jacob used this telescope for observing double stars, Jupiter and Saturn, and their satellites. Figure 8 shows Saturn as seen through the 6 inch Lerebours & Secretan equatorial by Jacob on 1853 January 1.

Pogson used this telescope and the later 8-inch equatorial by Troughton & Simms for his ambitious variable star atlas project and for discovering and observing minor planets.

In 1898 the telescope was remodelled by Sir Howard Grubb of Dublin. It was provided with an electrical drive, and a Grubb portrait lens of 5 inch aperture and 36 inch focus was attached to it¹¹.

In 1900 the telescope was installed in the north dome of the new building at Kodaikanal by C. Michie Smith who helped to fix the north and the south domes, personally driving some 2300 rivets¹¹.

The telescope was used for visual examination of the sunspots and chromosphere. In 1912 John Evershed replaced the object glass by a photovisual Cooke lens of the same (6 inches) aperture. The lens was in turn replaced by a visual achromatic lens of

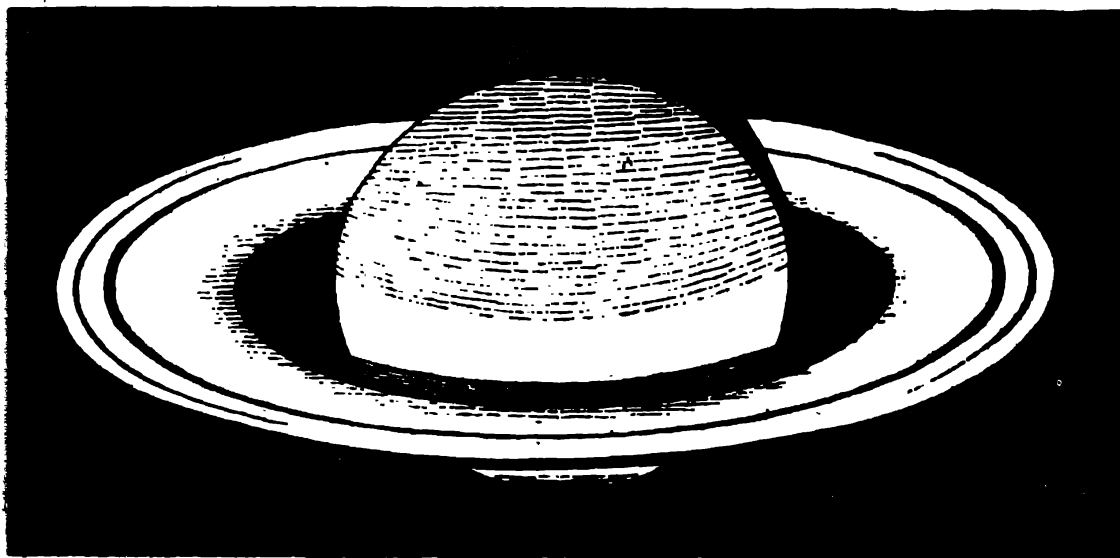

Figure 8. Saturn as seen by Jacob on 1853 January 1 through the six-inch equatorial¹⁰.

the same aperture and focal length, in 1918 by Evershed. Since 1912 the telescope has been used for direct daily photography of the sun, weather permitting.

3.3. *Transit circle by Troughton & Simms (1862)*

Since 1830 when the observatory acquired its transit instrument and mural circle, great strides had been made in meridional instrumentation⁵. In 1850 Greenwich Observatory acquired a transit circle, to yield both right ascension and zenith distance (or declination) on the same meridian transit. Made by Troughton & Simms of London to the design of G. B. Airy, it had an object glass of 8 inches aperture and 11 ft 7 inches focal length; the divided circle was 6 feet in diameter.

In 1852, Richard C. Carrington of Redhill had a transit circle constructed for him by Troughton & Simms. It was similar in all essential details to the Airy's transit circle, but smaller; it had a 5 inch object glass and a 42 inch divided circle. It is with this instrument that Carrington observed for his Circumpolar Catalogue of 3735 stars, published by Royal Society in 1857. In 1861 no longer required at Redhill, this transit circle was moved to Radcliffe Observatory, Oxford.

In 1855 on Jacob's recommendation, the court of directors of the East India Company placed an order with Troughton & Simms for a new transit circle, similar to the one by Carrington, who personally supervised the construction of the new instrument, suggesting improvements in the light of his own experience. The three transit circles—Airy's, Carrington's, and Madras Observatory's—were all divided by the same engine, and were presumably capable of giving equally accurate results.

The new transit circle arrived at Madras in 1858 March, only a month before Jacob's departure, and was installed by Pogson on 1862 June 1, with the help of the recently appointed Company Mathematical Instrument Maker, Mr F. Doderet, whose services were loaned to the observatory for the first half of 1862. Doderet also made a 5 ft telescope using the object glass of the old, 1830, transit instrument.

The new transit circle replaced the transit instrument and looked through the same slits in the roof and walls, which however were widened to 22 inches. Two brick piers were first erected for the transit circle, but were condemned by Major Worster (who officiated on Jacob's departure). They were replaced by excellent granite piers constructed under Tennant's supervision. Each of these piers measured $4\frac{1}{2}$ ft by 2 ft and was 4 ft high. Four capstones—each $4\frac{1}{4}$ ft long, 2 ft wide, and 2 ft 2 inches high—were sent out with the new instrument from England; and on two of these surmounted on the granite piers was placed the transit circle. The other two capstones supported the counterpoise arrangements. The clear space between the piers for the observer was 39 inches.

The clear aperture of the object glass was $5\frac{1}{2}$ inches and focal length about 50 inches. The magnification powers of the eyepieces were 105, 147, and 230. A Bohnenberger eyepiece, power 106, was also supplied with the instrument for determinations of the nadir point and level error.

The telescope eyepiece was provided with a system of seven vertical and one horizontal spiderline, moveable each way by micrometer screw of practically the

same thread. The single horizontal line was replaced by a close pair about 12" apart.

'A finder, 15 inches in length and $1\frac{1}{2}$ in aperture was added to the telescope, presumably for estimating the magnitudes of the brighter stars, but its utility for that or any other purpose is very questionable'⁵.

The two collimating telescopes were of $2\frac{3}{4}$ inch aperture and 35 inch focus.

In 1895 the circle was sent back to makers who replaced the old worn out gun metal screws of the microscopes with steel ones¹¹.

The transit circle continued to be at Madras till 1941, when it was dismantled and sent to Kodaikanal where it is now in a damaged condition; its objective glass having been used for the polar siderostat.

3.4. *Eight-inch equatorial by Troughton & Simms (1866)*

The new 8-inch equatorial was erected on the roof of the Astronomer's residence. It was enclosed in a revolving dome with an internal diameter of 16 ft, constructed by Messrs Leggett & Broomhall of Madras. The rotation of the dome was effected by means of eight 6-inch rollers, the axles of which were connected by a ring of hard wood, following a design by Mr Lassell of Liverpool (ref. 12).

The sliding shutters revealed an observing slit 3 ft in aperture, which extended over nearly two-thirds of the dome, or, from the horizon to about 25° beyond the zenith.

The telescope had a German mounting. The 8-inch object glass was critically tested and approved by the Astronomer Royal at Greenwich. It had a parallel-wire micrometer and a double-image micrometer designed by Mr G. B. Airy.

The two equatorials were used by Pogson for his work on variable stars, with magnification powers of 84, 52 and 70, and a field of view of over half a degree. Pogson used a number of reticles: 'a new reticle adapted for general use' (1859); 'a Smythian telescope reticle applied to the equatorial by Lerebours & Secretan' (1865); and finally 'a new reticle made by Messrs P. Cir & Co., Madras (1875) (ref. 13). In 1931 the telescope was shifted from Madras to Kodaikanal where it was installed in 1954. In 1960 it was erected by M. K. Vainu Bappu in the south dome on the mounting vacated by the 6 inch Cooke equatorial which it replaced. This Cooke equatorial was received in 1912 from the Takhtsinghji Observatory at Poona, and had in turn replaced another 6 inch Cooke equatorial which was installed by Mitchie Smith when the south dome was constructed in 1900.

3.5. *Nine-inch silver glass reflector by John Browning (1871-1875)*

The observatory had temporary use of the Browning reflector which was used by Colonel J. F. Tennant at Guntur during the total solar eclipse of 1868 August 18. It was altered, repaired and sent to Madras in 1871 on the advice of the Astronomer Royal for use at Avenashi (Coimbatore district) during total eclipse of 1871 December 12.

After the eclipse the reflector was installed on the historic Goldingham pillar in a room specially built for it. It was used during the annular solar eclipse of 1872

June 6. It was readied for photographing transit of Venus on 1874 December 8, but because of cloudy weather no photographs could be taken. The reflector was sent to Calcutta in 1875 February on the orders of Indian Government⁵.

4. Conclusions

We have described the observatory buildings, and the chief instruments of the observatory. Table 2 summarizes the results regarding the instruments.

Table 2. Chief instruments of Madras Observatory 1786–1899

< 1800	Sidereal clock (Shelton)
	12 inch circular instrument (Troughton)
	20 inch transit instrument (Stancliffe)
1830	5 ft focus, $3\frac{3}{4}$ inch aperture transit instrument (Dollond)
	4 ft diameter, $3\frac{3}{4}$ inch aperture mural circle (Dollond)
1850	Six-inch equatorial (Lerebours & Secretan)
1862	50 inch focus, $5\frac{1}{2}$ inch aperture transit (Troughton & Simms)
1866	Eight-inch equatorial (Troughton & Simms)

Acknowledgements

I thank Dr J. C. Bhattacharyya who suggested that I take up a study of the history of Indian Institute of Astrophysics and provided all help. Mr K. S. Balasubramaniam and Dr K. K. Scaria were of great help. Valuable assistance was provided by Messers. Aleem, Irulappan, Chockalingam, and many others. I thank Mrs M. I. Morris for copy of the John Warren's letter.

References

1. Kochhar, R. K. (1985) *Bull. Astr. Soc. India* 13, 162; *Curr. Sci.* 54, 892.
- 1a. Phillimore, R. H. (1950) *Historical Records of Survey of India*, Vol. 2, Survey of India, Dehra Dun.
2. Markham, Clemens R. (1878) *A Memoir on the Indian Surveys* (2nd edn), (sold by) W. H. Allen & Co., London.
3. Manuscript Volume by John Goldingham, 1792, IIA Archives.
- 4a. Taylor, T. G. (1832) *Madras Astronomical Observations*, Vol. 1 (for 1831), Madras Observatory.
- 4b. Taylor, T. G. (1835) *Madras Astronomical Observations*, Vol. 2 (for 1832 & 33), Madras Observatory.
- 4c. Taylor, T. G. (1848) *Madras Astronomical Observations*, Vol. 7 (for 1843–47), Madras Observatory.
5. Pogson, N. R. (1887) *Madras Meridian Circle Observations for 1862–64*, Madras Observatory.
- 6a,b. Manuscript Records 1794–1812, IIA Archives, p. 48; p. 202.
7. Goldingham, J. (1822) *Phil. Trans.* 127–170.
8. John Warren's letter dated 1807 March 5 to Colonel George Harcourt, Personal collection of Mrs M. I. Morris, Edinburgh.

9. N. R. Pogson's report of 1867 February 25 to the Chief Secretary, Madras Govt., Madras Observatory Government Orders 1857-1897, IIA Archives, p. 138.
10. Worster, W. K. & Jacob, W. S. (1855) *Madras Astronomical Observations*, Vol. 8 (for 1848-52), Madras Observatory.
11. Madras/Kodaikanal Observatory Annual Report 1895; 1898; 1900; 1912.
12. *M.N.R.A.S.* (1859) 19, 35.
13. *M.N.R.A.S.* (1898) 59, 57.