

## A new computer-controlled multi-channel high voltage supply system for GRACE instrumentation

A.Manna, S. Chakrabarti and P.Mukhopadhyay

*Bhabha Atomic Research Centre, Electronics Division, Mumbai-40008, India.*

**Abstract :** The high energy gamma ray telescopes being set up by the Bhabha Atomic Research Centre (BARC) at Mt. Abu, Rajasthan, as part of the GRACE project, require a very large number (~ 1000 ) of programmable high voltage power supplies for biasing photomultiplier tubes for the detection and characterization of the atmospheric Cerenkov events. These HV supplies need to be very compact, lightweight and rugged, as they will be mounted on the base of the moving telescopes. This paper describes the design aspects of the overall HV system and the performance of the prototype HV modules developed for such applications. In the new design, the inverter switching frequency of the HV supplies has been increased threefold as compared to the earlier design, and surface mounted devices have been used to achieve overall size and weight reductions. The system consists of multiple HV modules, each containing 16 independently programmable HV supplies. Each HV module has an on-board micro-controller for doing control and supervisory functions and is interconnected via a serial I<sup>2</sup>C bus. The HV supplies have built in over voltage/current, thermal overload protections with output voltage readback and adjustable slew rate control facilities.

*Key words :* GRACE Project, HV supply, Instrumentation

### 1. Introduction

The Nuclear Research Laboratory Division of the BARC, is setting up a series of high-energy gamma ray telescopes for detecting cosmic gamma-ray sources at energies beyond 20GeV. These telescopes will employ a large number of photo-multiplier tubes for imaging these events. The HV bias supplies for these photo-multiplier tubes are required to have fine voltage resolution to establish close channel to channel gain matching. This requirement has led to the development of programmable HV supplies where the user sets the demand digitally to produce a desired output voltage accurately. Adjustment and monitoring of such a large number of high voltage supplies via computer becomes a necessity and provides additional benefits by locating the HV supplies closer to the telescope, thus minimizing cable runs and providing major cost and labour savings.

A multi-channel, high voltage system consisting of about 600 HV channels, developed for the TACTIC telescope [1], is presently operational at Mount Abu, Rajasthan. For the upcoming MACE telescope a new high voltage supply system has been designed that will be mounted on the base of the moving telescope. For achieving compact size and reduced weight, the inverter switching frequency of the HV supplies has been increased three fold as compared to the earlier system. This has been made possible by the use of low on-resistance MOSFETs, low loss ferrites and adopting a zero voltage resonant switching technique. For safe and reliable operations of the HV system, each supply is provided with over voltage, over current and thermal overload protections and has output voltage read-back as well as adjustable slew-rate control facilities. A serial Inter IC (I<sup>2</sup>C) bus has been chosen for networking the HV modules to reduce the number of interconnections in the system. The simple bus protocol of the I<sup>2</sup>C that is supported by the on-chip bus interface logic of the micro-controller allows for low cost and flexible system design with easy scope for future expansion.

### 2. System description

The computer controlled multi-channel high voltage power supply system is designed for

modular construction and comprises multiple HV modules each containing 16 independently adjustable HV supplies. 16 such HV modules (i.e., 256 HV channels) are housed in a 19", 10U height rack mount chassis. The HV modules communicate via I<sup>2</sup>C serial bus (Fig. 1) with a master controller node. The overall HV system is networked to an Ethernet that is shared by other Grace Electronic Modules (GEM) of the telescope for data communication and control purpose.

The output voltage of each supply is independently programmable in the range of 0 to 2000V with a maximum output current capability of 1 mA. Each HV supply consists of a high frequency step-up push pull inverter, a Cockcroft - Walton HV multiplier and an error amplifier in a feedback loop (Fig. 2). R-C filters are used to attenuate the output ripple at the inverter switching frequency.

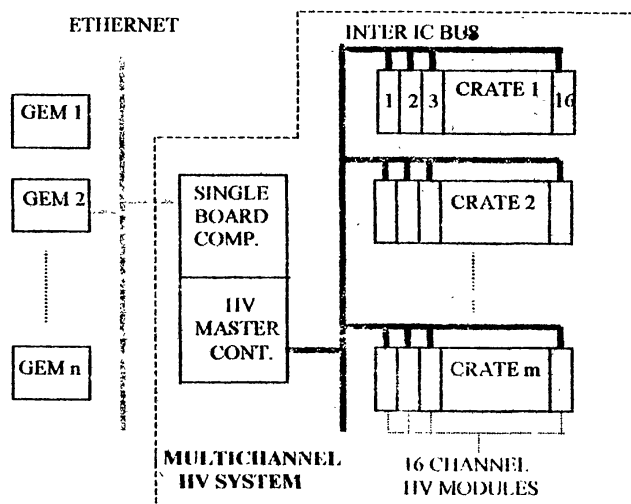

Fig. 1: Schematic diagram of the new HV system

A zero voltage resonant switching technique has been used to reduce switching losses in the MOSFETs. The switches M1 and M2 are turned on when it's drain to source voltage is zero, thereby eliminating the turn-on losses. The magnetizing inductance of the HV transformer together with the secondary winding capacitance sets the resonant frequency of operation and is a tightly controlled parameter in the design. The use of low loss ferrite cores and low on-resistance MOSFETs has enabled the operation of the inverters at a switching frequency of 70 kHz that is three times higher than the earlier design. This, along with the use of surface mount devices has resulted in smaller and lighter HV supplies. The size of the new HV system is nearly half of that of the earlier system for the same number of HV channels.

Each HV module contains an on-board 8-bit micro-controller (Philips 80C552) and it's associated control / interface circuitry (Fig.3). The reference voltages of all the 16 HV supplies on a module are independently adjusted through a set of four 12 bit quad DAC's. A 12-bit successive approximation ADC with a 16-input multiplexer reads the actual output voltages of all the HV supplies in a module. In case of an over-voltage or an overload conditions, independent protection logic shuts down the corresponding power supply. Over voltage limit is adjustable through hardware and is same for all the supplies on a HV module. In addition, each HV module has a thermal overload detector and a heat-sink temperature monitoring circuit for added protection of the supplies. The individual 'ON / OFF' status of each supply is registered in a 'SHUT DOWN' flip-flop and is also available as a system information.

The on-board micro-controller features two built-in serial interfaces, i.e., RS-232C and I<sup>2</sup>C. All the HV modules in the system are designed to share a serial I<sup>2</sup>C bus for communication and control purposes. The I<sup>2</sup>C bus can support a data flow rate of up to 100 KBits / second and requires only two lines to connect all the devices. Each HV module of the system is assigned a unique address on the bus and exchanges data in a master / slave mode. The main HV controller node receives control commands from other GEMs via Ethernet and puts it on the I<sup>2</sup>C bus. The HV module, which is addressed in the control command, responds to the call and executes it. Because I<sup>2</sup>C bus has true multi-master capability, all the modules are capable of drawing attention of the system controller under abnormal conditions

by switching into the master mode. I<sup>2</sup>C bus extenders have been used on each module to extend the physical length of the bus as well as to accommodate larger number of HV modules in the system.

The on-board micro-controller features two built-in serial interfaces, i. e., RS-232C and I<sup>2</sup>C. All the HV modules in the system are designed to share a serial I<sup>2</sup>C bus for communication and control purposes. The I<sup>2</sup>C bus can support a data flow rate of up to 100 KBits / second and requires only two lines to connect all the devices. Each HV module of the system is assigned a unique address on the bus and exchanges data in a master / slave mode. The main HV controller node receives control commands from other GEMs via Ethernet and puts it on the I<sup>2</sup>C bus. The HV module, which is addressed in the control command, responds to the call and executes it. Because I<sup>2</sup>C bus has true multi-master capability, all the modules are capable of drawing attention of the system controller under abnormal conditions by switching into the master mode. I<sup>2</sup>C bus extenders have been used on each module to extend the physical length of the bus as well as to accommodate larger number of HV modules in the system.

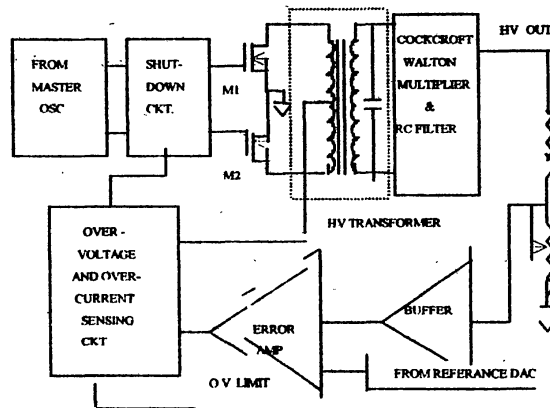

Fig.2 Schematic diagram of a HV supply

Some of the salient features of the HV supplies are:

- Independent output voltage adjustability of all the supplies in the range from 0 to 2 KV with a setting resolution of 1V
- All the supply outputs are rapidly reduced to zero on receiving the panic-off signal
- Output voltage read-back facility with 12-bit resolution
- Status monitoring facility of each HV supply.
- Ramp up/ down rates of the HV supplies adjustable under software control

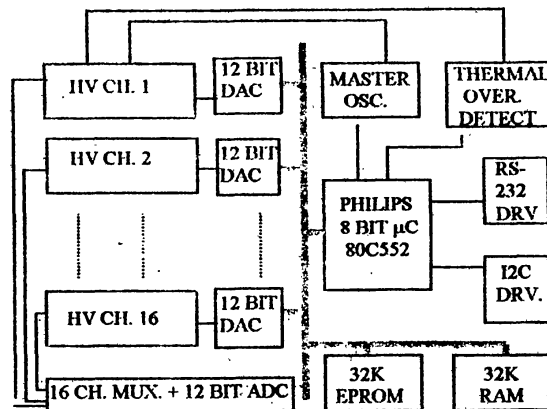

Fig. 3: Block diagram of a 16-channel HV module

### 3. Design evaluation

A few design prototypes of the high voltage supplies have been tested. The development of a production prototype is under progress. In the new design, low output ripple and noise have been achieved through careful PCB layout, component placement and judicious shielding of sensitive circuits. A prototype version of the microcontroller based HV interface/ control circuitry has been tested and was found to meet design requirements. The driver routines for the I<sup>2</sup>C interface has been developed and communications established over a distance of few tens of meters, which has been made possible due to the use of bus extender chips.

Some observed performances of the HV supplies are:

- Output voltage adjustability from 0 to 2 KV at 1mA output current with 1V setting resolution
- Output ripple voltage at full load < 50 mV (p-p).
- Load regulation better than 0.01%.
- Temperature instability of o/p voltage < 100 ppm / °C.
- Long-term instability < 0.02 % per day.

### 4. Conclusions

A prototype development of a new Multi-channel HV supply system has been carried out. The inverter switching frequency of the HV supplies has been increased by three times, which has resulted in smaller size and weight of the overall HV system. The system has been designed for modular construction with easy scope for future expansion. A serial I<sup>2</sup>C bus that requires only two lines has been adopted for interconnecting all the HV modules in the system. Though the I<sup>2</sup>C bus is single ended it was chosen for its simple bus protocols supported by the on-chip interface logic of the micro-controller. The integrated addressing and data transfer protocols of the I<sup>2</sup>C bus allow for flexible system design at a low cost.

### Acknowledgement

The authors are grateful to Dr. S. K. Kataria, Head, Electronics Division, Dr. C.L.Bhat, Head, NRL, and Shri R. Kaul, NRL for their encouragement and support for this work.

### References

1. A.Manna, P.K. Mukhopadhyay, B.R.Bairi, "Computer Controlled Multiple Channel High Voltage Power Supply ". Proceedings of National Symposium on Advanced Instrumentation for Nuclear Research, Jan 27-29, 1993.
2. Philips Semiconductor Manual, 1997